

Variable Attenuators

Three attenuator module choices to meet your range requirements

Variable attenuators are a key element in achieving dynamic range capability of the HELIOS®Plus family of systems. Essentially, the products provide a mechanical blade that blocks the light input from the source to the sphere and thereby provides very precise control of sphere radiance.

The spectrally neutral blades (black or aluminum) close the port like an iris port while minimizing color shifts in the output spectrum. Labsphere offers three exception models (VAA, VAD and VAM) that represent trade-offs between automation, resolution performance and price to suit customer projects. Attenuator designs also include flat and asymmetric blades that enhance dynamic range.



VAD – Dynamic Variable Attenuator

Our most frequently used attenuator offers a superb mix of performance and range suitable for most 12-bit cameras and sensors. The VAD is an incredibly robust design that provides very predictable and durable automated performance.



VAA – Advanced Variable Attenuator

The complete package – an optically encoded electromagnetic drive with fast closure and incredible step resolution. The VAA also provides our best light sealing as well as an incredible 8 orders or dynamic range. If you need the best performance you can get the VAA is unparalleled performance.

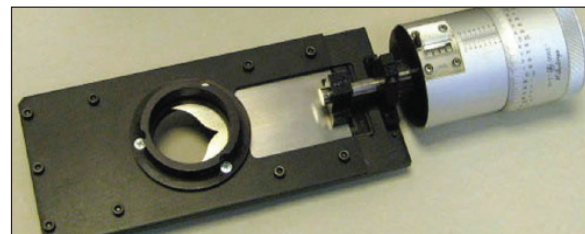

VAM – Manual Micrometer Variable Attenuator

When speed and automation are not needed for your testing requirements the VAM is a perfect balance of precision, range and control. This unit features a Mitutoyo micrometer drive system with indexed counter for easy visibility and attenuator position control.

Notes on Variable Attenuators & Feedback Control

The automated variable attenuator models (VAD and VAA) can be used in conjunction with the system detectors to perform closed loop control or level seeking actions. The accuracy and specifications of these routines (and system scripts) is highly dependent on the user's desired operation. HELIOSense Software enables several scripting patterns for using closed loop solutions.

Specifications

VA Feature	VAA-220A - Advanced	VAA-220B - Advanced	VAD-012 - Dynamic	VAM-010 - Manual
Controller:	Yes	Yes	Yes	No
Maximum Number of Steps:	2,200,000	2,200,000	12,000	10,000
Approximate Dynamic Range:	1.00E+07	1.00E+07	1.20E+04	5.00E+04
Shutter Closure Level:	1.00E-07	1.00E-07	1.00E-03	1.00E-03
Blade Type:	Logarithmic Tear-Drop	Logarithmic Tear-Drop	Straight Edge	Logarithmic Tear-Drop
Blade Finish:	Aluminum	Optical Black	Aluminum	Aluminum
Full Open to Full Close Speed:	<1.5 s	<1.5 s	11 s	Manual
Optically Encoded:	Yes	Yes	No	No
Home for Position Setting:	Not Required	Not Required	Required	N/A
Micrometer Vernier:	No	No	No	Yes
Rated AC Input/Frequency:	100-240 VAC, 47-63 Hz	100-240 VAC, 47-63 Hz	100-240 VAC, 47-63 Hz	100-240 VAC, 47-63 Hz
Operating Temperature Range:	10 to 40°C	10 to 40°C	10 to 40°C	10 to 40°C
Storage Temperature Range:	-20°C to 70°C	-20°C to 70°C	-20°C to 70°C	-20°C to 70°C
Operating Temperature RH%:	30 - 90% (no condensation)	30 - 90% (no condensation)	30 - 90% (no condensation)	30 - 90% (no condensation)
Storage Temperature RH%:	10 - 95% (no condensation)	10 - 95% (no condensation)	10 - 95% (no condensation)	10 - 95% (no condensation)
Controller Required:	Yes, VAA-MC	Yes, VAA-MC	Yes, VAD-MC	No
Cable:	Encoder & Drive	Encoder & Drive	Drive	None
Compliance:	CE, RoHS	CE, RoHS	CE, RoHS	CE, RoHS
Standard Warranty:	1 year	1 year	1 year	1 year

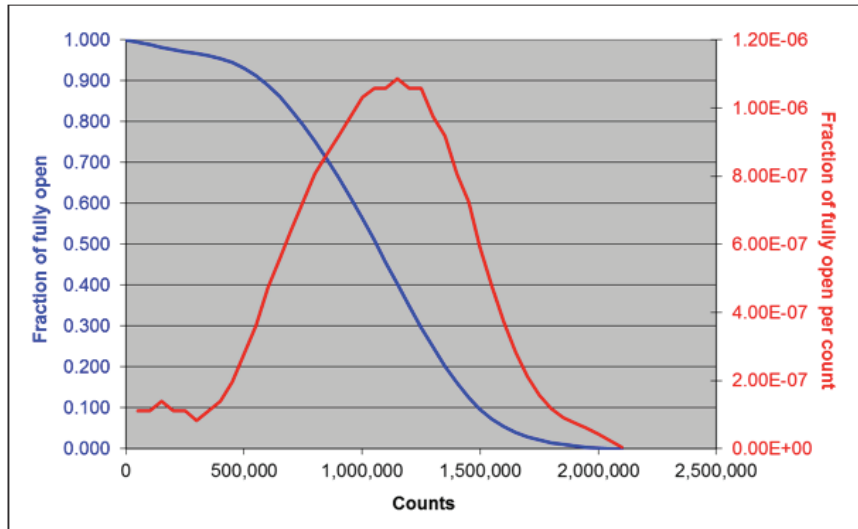

VAA Steps vs Throughput Shape (Satellite Sphere Input)

VA Dimensional Drawing

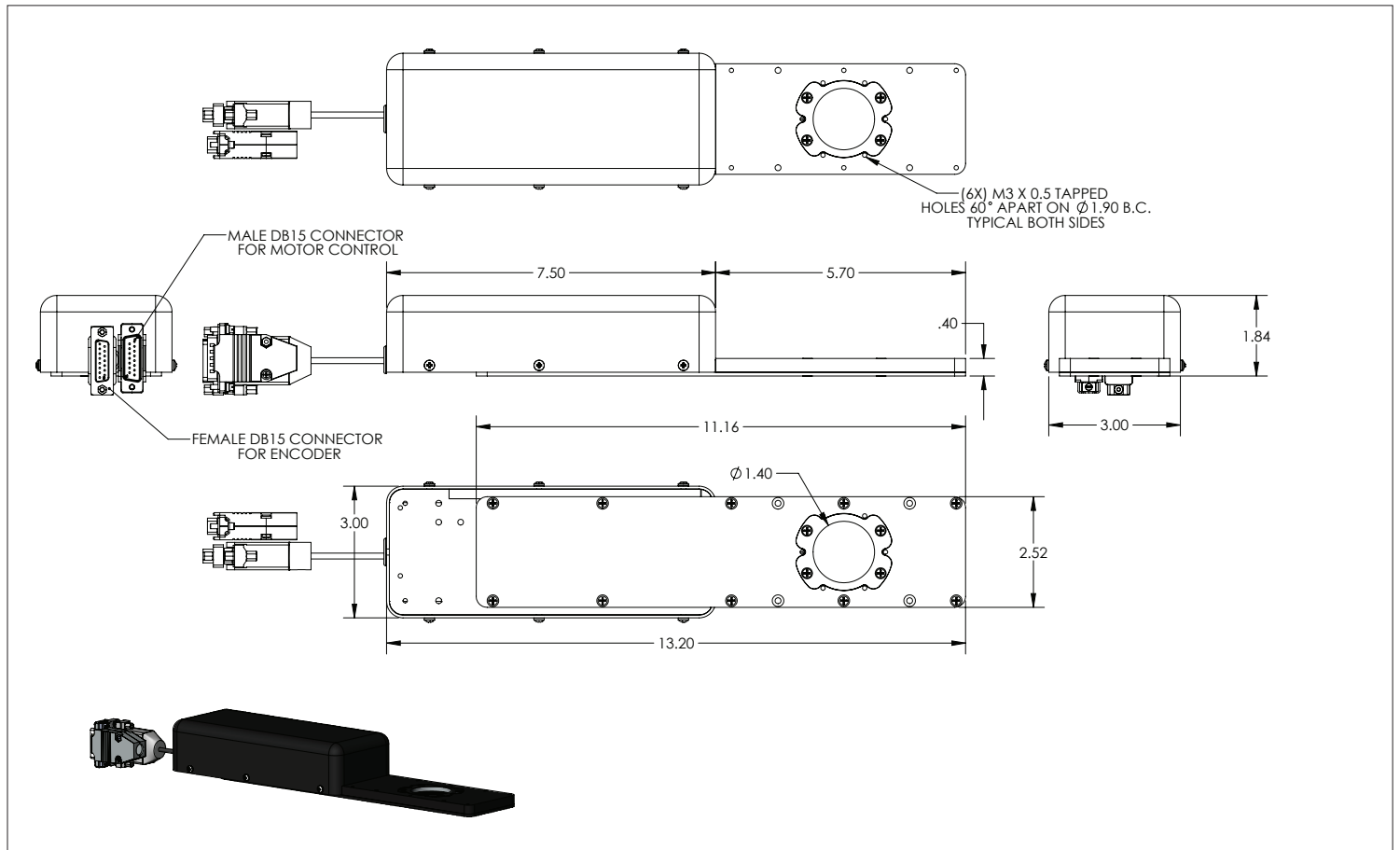

VAM Dimensional Drawing

